

## Tape-Stitching Presser Foot

Remove your regular presser foot and place the Tape-Stitching Presser Foot on.

You have two screws which create your adjustments.

#6 - adjusts your stitch position - where you want your needle to enter your fabric

#5 - adjusts to fit your bias binding - adjust so that this width is the width of your binding. You will notice it moving in or out accordingly.

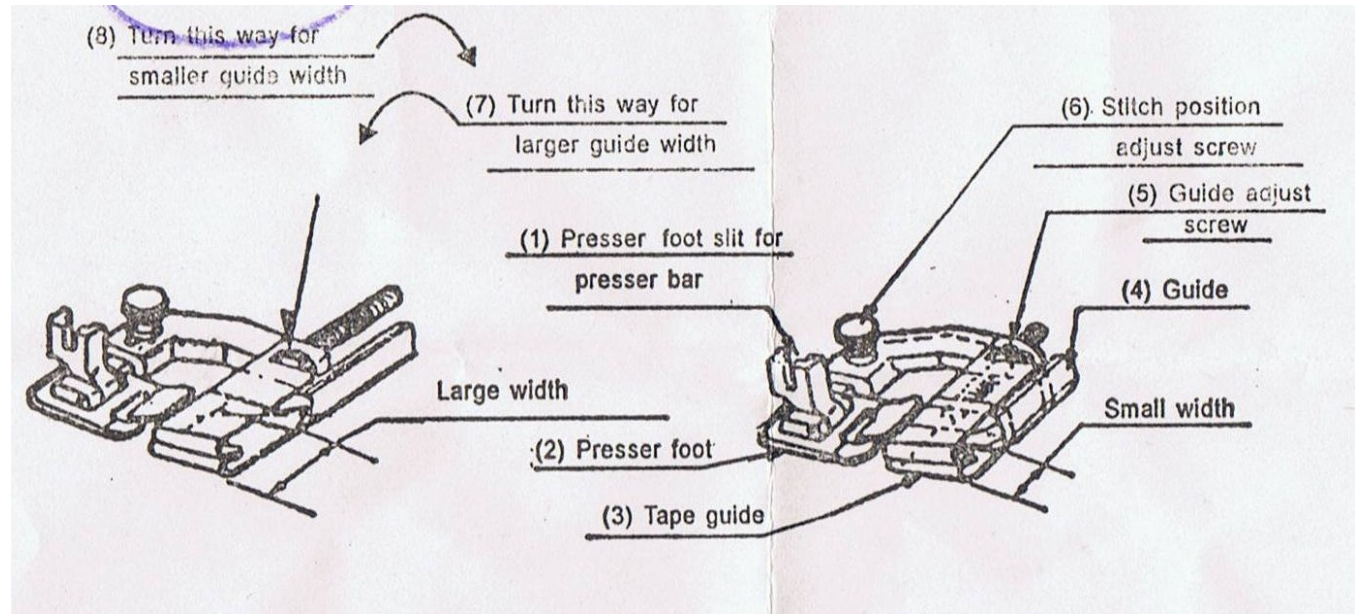

Turn the guide adjustment screw away from you to increase the guide width (and toward you to decrease the width).

Insert the tape from the corner and turn toward the back of presser bar. You are ensuring the top fold is in the top slit and the bottom fold in the bottom slit.

Tip: I actually slide the bias binding in and just wiggle it around. Now, take a look. Is the top half of your binding in the top groove? Is the bottom half of your binding in the bottom groove? Great! You are ready to insert the fabric.

Recheck your guide adjustment screw to ensure it is against the tape.

Loosen the stitch position adjustment screw and adjust the position of the tape guide (3) to place the cloth in position to be stitched. Lower your needle ensuring your stitching is against the edge of the bias tape, if not, readjust accordingly.

Place your cloth to be taped in position; ensure all screws are tightened.

Hold the tape and the cloth by your hands, one in front and one behind the presser bar; start stitching slowly at first.

### Tips

- To ensure the tape stays in the guide, I hold it up a bit as it enters the guide.
- You can use an selection of tape width within 3mm to 20mm.
- This does not prepare the tape as you stitch; used solely for applying pre-folded tape.

**Happy Stitching!**

**Charlene**  
**THE SEW BOX**  
[www.theseinbox.com](http://www.theseinbox.com)

the next page are the manufacturer's instructions, which I hope I have simplified for you.

## Tape-Stitching Presser Foot

6287(low), 6288(High), 6289(Slant), 6290(Snap-

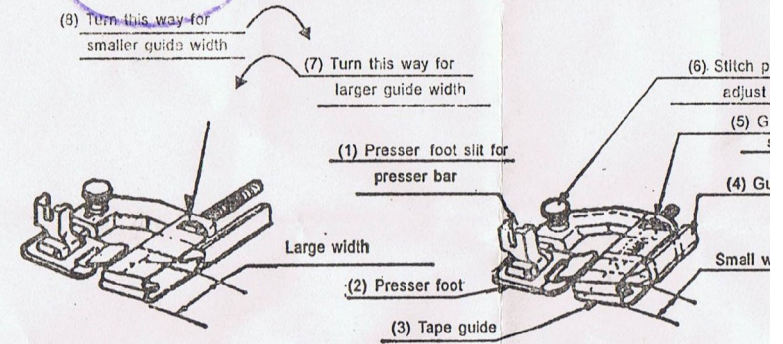

### I. How to Fix the Tape-Stitching Presser Foot

1. Fit the presser bar (11) into the slit (1) and firmly tighten the presser foot screw (13).
2. Turn the guide adjustment screw (5) away from the user, i.e., in a direction shown in (7) to increase the guide width.
3. Insert the tape from the corner (9) and run it in the direction of arrow (10) to place it in position.
4. Turn the guide adjustment screw (5) toward the user, i.e., in a direction shown in (8) to narrow the tape.
5. Loosen the stitch position adjustment screw (6) and adjust the position of the tape guide (3) to place the cloth in position for being stitched. After the tape guide (3) is in position, tighten the stitch position adjustment screw (6).
6. Hold the tape and the cloth by both hands, and start stitching slowly at the beginning.

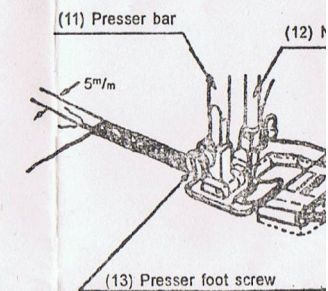
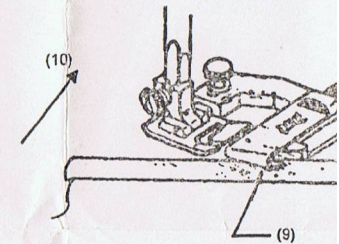

### II. Selection of Tape Width

1. Selection of tape width is possible within 3mm-20mm.
2. Use any prepared folded-in-three bias tape.

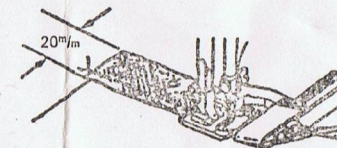

**NOTE:** This tape-stitching presser foot cannot be used for stitching while preparing a tape folded in three.